



TRI-T COMPANY LIMITED

**SPECIFICATION
FOR
COG MODULE**

ORDER NO : TMTG320240D-02

MODULE NO.: TMTG320240D-F-FC-LED05-W

DOC.REVISION A01

Customer Approval:

--

	NAME	SIGNATURE	DATE
PREPARED BY	KOWK SHING FU		19 JUN 2007
CHECKED BY	FU SZE HOI		19 JUN 2007
APPROVED BY	FU SZE HOI		19 JUN 2007



TRI-T COMPANY LIMITED

DOCUMENT REVISION HISTORY

Version	DATE	DESCRIPTION	CHANGED BY
A00	06 OCT 2005	First issue	
A01	19 JUN 2007	Update mechanical drawing on page 1	Kowk Shing Fu



Dimensional Outline	1
Functions & Features	2
Mechanical Specifications	2
Block Diagram	3
Pin Description	4
Power Supply	5
Maximum Absolute Limit	6
Electrical Characteristics	6 ~ 9
Backlight Specification	10
Control and Display Commands	11 ~12
Display Data RAM Addressing	13
Electro-Optical Characteristics	14
Quality Specifications	15-22



1. DIMENSIONAL OUTLINE

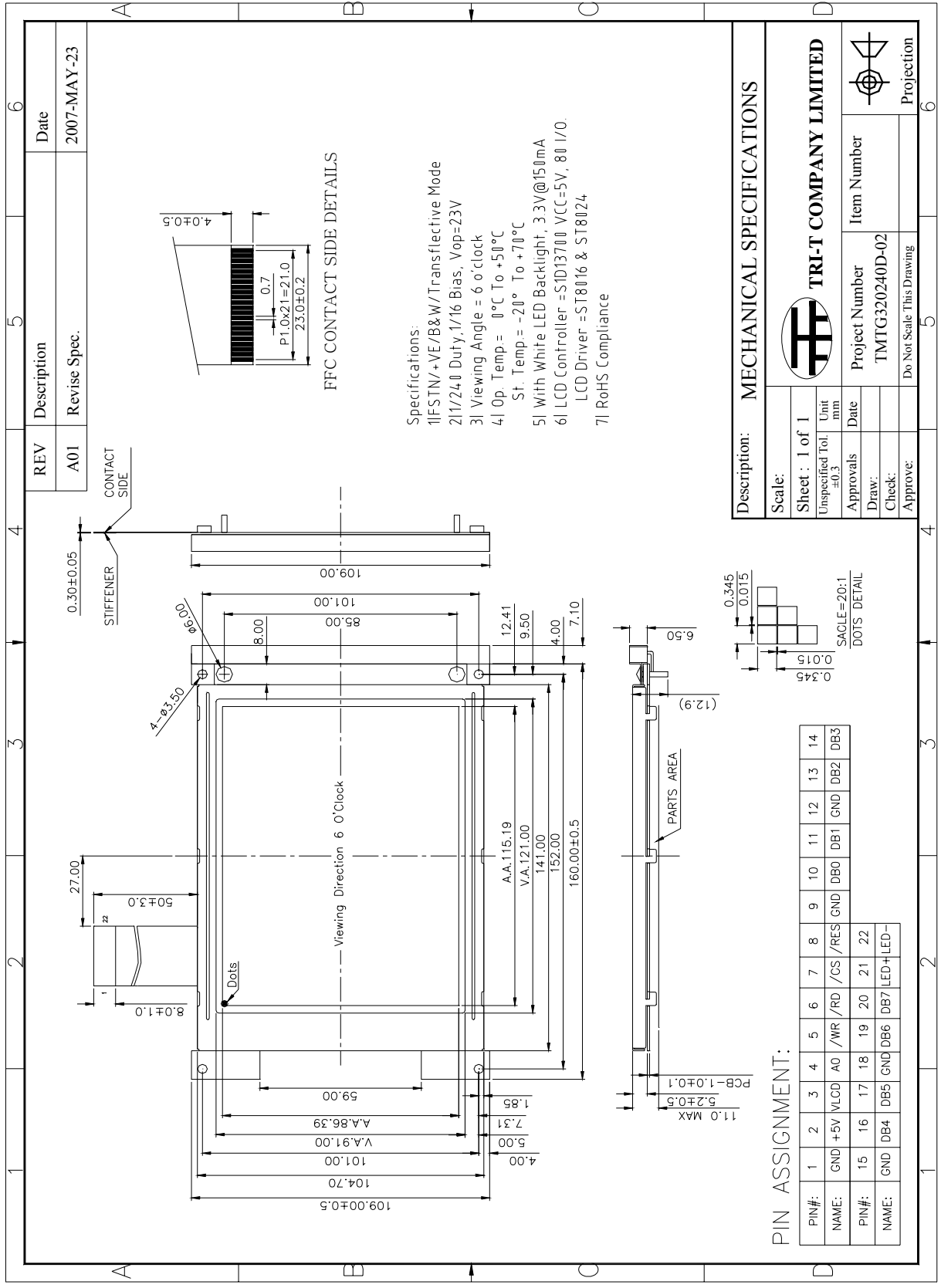



2.FUNCTIONS & FEATURES

- 2-1. Format : 320*240 dots
- 2-2. LCD Mode : FSTN/+VE/Transflective Mode
- 2-3. Viewing Direction : 6 o'clock
- 2-4. Driving Scheme : 1/240 Duty cycle, 1/16 Bias
- 2-5. Single Supply Voltage : Power supply voltage range (V_{DD}): 2.7~5.5V
- 2-6. With LED Backlight, Color : White
- 2-7. 8080 Serie Parallel Interface
- 2-10. On-Board DC-DC Converter
- 2-11. RoHs Compliance

3.MECHANICAL SPECIFICATIONS

- 3-1. Module size : 167.1mm(L)* 109.0mm(W) *11.0mm(D)(not include FPC)
- 3-2. Viewing area : 121.0mm(L)* 91.0mm(W)
- 3-3. Active area : 115.19mm(L)* 86.39mm(W)
- 3-4. Dot pitch : 0.36mm(L)*0.36mm(W)
- 3-5. Dot size : 0.345mm(L)*0.345mm(W)



4.BLOCK DIAGRAM

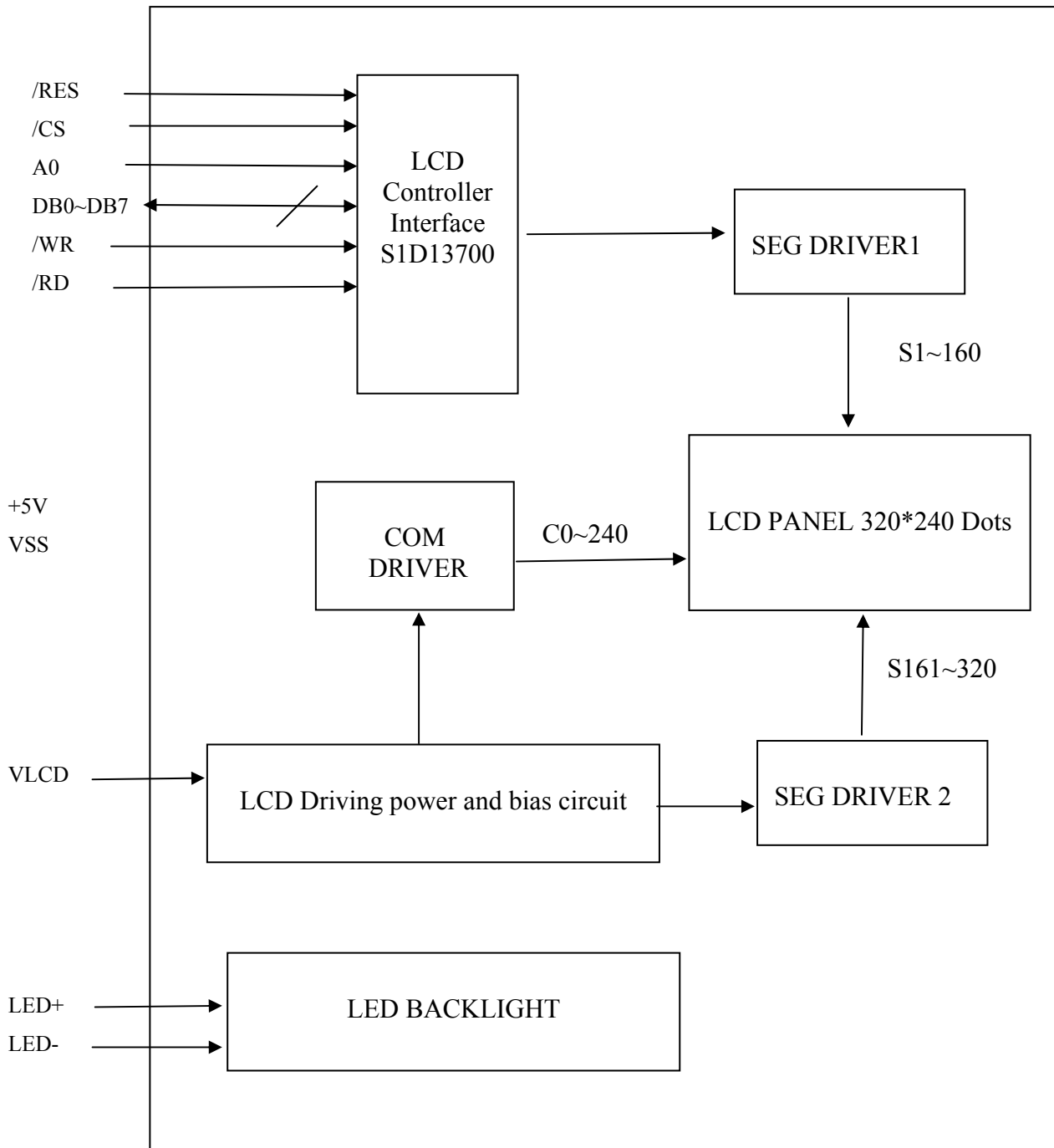



5. PIN DESCRIPTION

1	VSS	Ground
2	+5V	Supply voltage for logic circuit
3	VLCD	LCD contrast control pin,
4	A0	Data type select
5	/WR	8080 family: Read signal, low active
6	/RD	8080 family: Write signal, low active
7	/CS	Chip select
8	/RES	Reset
9	GND	Ground
10	DB0	8-bit bi-directional data bus
11	DB1	
12	GND	
13	DB2	8-bit bi-directional data bus
14	DB3	
15	GND	Negative voltage supply pin
16	DB4	8-bit bi-` data bus
17	DB5	
18	GND	Ground
19	DB6	8-bit bi-directional data bus
20	DB7	
21	LED+	Anode of LED backlight, +3.3V
22	LED-	Cathode of LED backlight, 0V

6. POWER SUPPLY

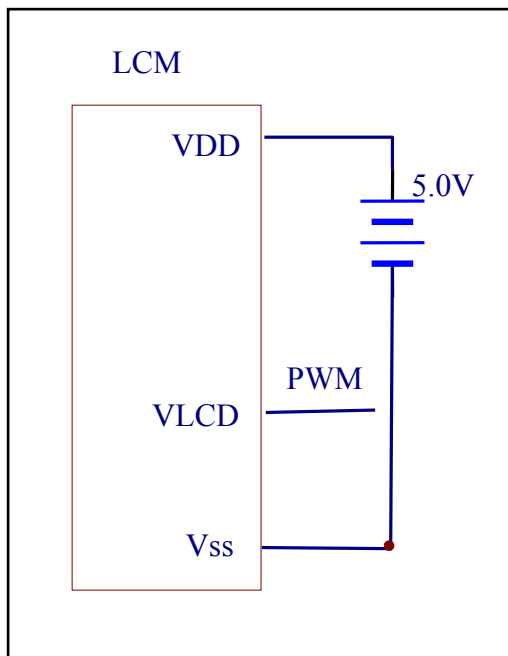

OR

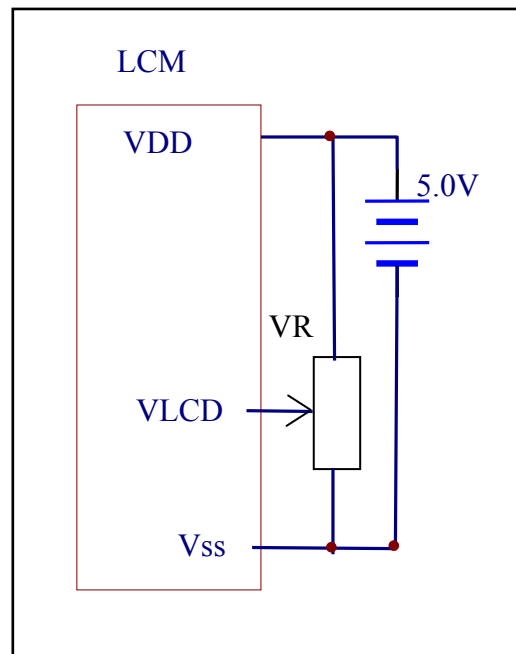

i) PWM= Pulse Width Modulation, 50% duty cycle

ii) VR=47 kohm

VLCD is the control pin for adjusting the LCD contrast.



7. MAXIMUM ABSOLUTE LIMIT (T=25°C)

Item	Symbol	Standard value	Unit
Supply Voltage	CORE VDD	VSS-0.3 to +4.0	V
Supply Voltage	IO VDD	VSS-0.3 to +7.0	V
Input voltage	V _{IN}	VSS-0.3 to IO VDD +0.5	V
Output Voltage	V _{out}	VSS-0.3 to IO VDD +0.5	V
Operating temperature	Topr	0~+50	°C
Storage temperature	Tstg	-20~+70	°C

Note: Voltage greater than above may damage the module

8. ELECTRICAL CHARACTERISTICS

8-1. DC Characteristics (V_{DD} = 4.5 to 5.5V, V_{SS} = 0V, T_a = -20 to 75°C)

Symbol	Parameter	Rating				Test condition
		Min	Typ	Max	Unit	
Core V _{DD}	Supply Voltage	3.0	3.3	3.6	V	VSS=0V
HIO V _{DD}	Host Bus IO Supply Voltage	4.5	5.0	5.5	V	VSS=0V
HIO V _{DD}	Panel supply voltage	4.5	5.0	5.5	V	VSS=0V
I _{DD}	Logic current	-	30	50	mA	DC/DC Converter On
HIO V _{IN}	Host Input Voltage	VSS	-	HIO V _{DD}	V	
NIO V _{IN}	Non-Host Input Voltage	VSS	-	NIO VDD	V	
I _{LZ}	Input Leakage Current	-1	-	1	uA	
I _{OZ}	Output Leakage Current	-1	-	1	uA	
V _{OH}	High Level Output Voltage	VDD-0.4	-	-	V	VDD=min. IOH=-6mA
V _{OL}	Low Level Output Voltage	-	-	0.4	V	VDD=min. IOH= 6mA
V _{IH1}	High Level Input Voltage	2.0	-	-	V	LVTTTL LEVEL, VDD=max
V _{IL1}	Low Level Input Voltage	-	-	0.8	V	LVTTTL LEVEL, VDD=min.
V _{T+}	High Level Input Voltage	1.1	-	2.4	V	LVTTTL Schmitt
V _{T-}	Low Level Input Voltage	0.6	-	1.8	V	LVTTTL Schmitt
V _{H1}	Hysteresis Voltage	0.1	-	-	V	LVTTTL Schmitt
R _{PD}	Pull Down Resistance	2.0	50	120	K ohm	



8-2-1. Parallel Read/Write Characteristics (8080-series)

Ta = -20 to 75°C

Signal	Symbol	Parameter	VDD = 4.5 to 5.5V		VDD = 2.7 to 4.5V		Unit	Condition
			min	max	min	max		
A0, CS	tAH8	Address hold time	10	—	10	—	ns	CL = 100pF
	tAW8	Address setup time	0	—	0	—		
— WR, — RD	tCYC8	System cycle time	See note.	—	See note.	—		
	tCC	Strobe pulsewidth	120	—	150	—		
D0 to D7	tDS8	Data setup time	120	—	120	—		
	tDH8	Data hold time	5	—	5	—		
	tACC8	RD access time	—	50	—	80		
	tOH8	Output disable time	10	50	10	55		

Note: For memory control and system control commands: tCYC8 = 2tC + tCC + tCEA + 75 > tACV + 245 For all other commands: tCYC8 = 4tC + tCC + 30

8-2-2 8080 family interface timing

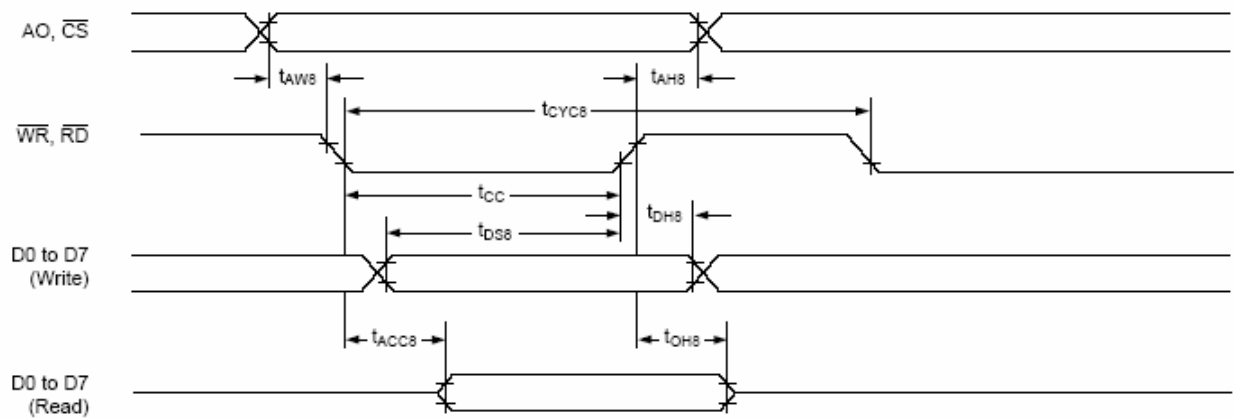



9.BACKLIGHT SPECIFICATIONS

9-1.Absolute maximum rating

Item	Symbol	Ratings	Unit
Peak forward current	I _{fp}	250	mA
Reverse voltage	V _r	1.0	V
Power dissipation	P _d	1200	mW

9-2.Electrical specifications

Item	Symbol	Min	Type	Max	Unit	Conditions
Luminous intensity	L _v	-	150	-	cd/m ²	IF=150mA Ta=25°C
Peak emission wavelength	λ _p	-	-	-	nm	
Spectral line half width	Δλ	-	-	-	nm	
Forward voltage	V _f	3.0	3.3	3.6	V	
Reverse current	I _r	-	35	-	mA	VR=0.8V



10. CONTROL AND DISPLAY COMMAND

Class	Command	Code											Hex	Command Description	No. of Bytes	
		— RD	— WR	A 0	D 7	D 6	D 5	D 4	D 3	D 2	D 1	D 0				
System control	SYSTEM SET	1	0	1	0	1	0	0	0	0	0	0	0	40	Initialize device and display	8
	SLEEP IN	1	0	1	0	1	0	1	0	0	1	1	53	Enter standby mode	0	
Display control	DISP ON/OFF	1	0	1	0	1	0	1	1	0	0	D	58, 59	Enable and disable display and display flashing	1	
	SCROLL	1	0	1	0	1	0	0	0	1	0	0	44	Set display start address and display regions	10	
	CSRFORM	1	0	1	0	1	0	1	1	1	0	1	5D	Set cursor type	2	
	CGRAM ADR	1	0	1	0	1	0	1	1	1	0	0	5C	Set start address of character generator RAM	2	
	CSRDIR	1	0	1	0	1	0	0	1	1	C D 1	C D 0	4C to 4F	Set direction of cursor movement	0	
	HDOT SCR	1	0	1	0	1	0	1	1	0	1	0	5A	Set horizontal scroll position	1	
OVLAY	1	0	1	0	1	0	1	1	0	1	1	5B	Set display overlay format	1		
Drawing control	CSRW	1	0	1	0	1	0	0	0	1	1	0	46	Set cursor address	2	
	CSRR	1	0	1	0	1	0	0	0	1	1	1	47	Read cursor address	2	
Memory control	MWRITE	1	0	1	0	1	0	0	0	0	1	0	42	Write to display memory	—	
	MREAD	1	0	1	0	1	0	0	0	0	1	1	43	Read from display memory	—	

Notes:

- In general, the internal registers of the SED1335 series are modified as each command parameter is input. However, the microprocessor does not have to set all the parameters of a command and may send a new command before all parameters have been input. The internal registers for the parameters that have been input will have been changed but the remaining parameter registers are unchanged.
 - 1.2-byte parameters (where two bytes are treated as 1 data item) are handled as follows:
 - CSRW, CSRR: Each byte is processed individually. The microprocessor may read or write just the low byte of the cursor address.
 - SYSTEM SET, SCROLL, CGRAM ADR: Both parameter bytes are processed together. If the command is changed after half of the parameter has been input, the single byte is ignored.
- APL and APH are 2-byte parameters, but are treated as two 1-byte parameters.



11. INTERNAL CHARACTER GENERATOR FONT

		Character code bits 0 to 3															
		0	1	2	3	4	5	6	7	8	9	A	B	C	D	E	F
Character code bits 4 to 7	2		!	"	#	\$	%	&	'	()	*	+	,	-	.	/
	3	0	1	2	3	4	5	6	7	8	9	:	;	<	=	>	?
	4	a	b	c	d	e	f	g	h	i	j	k	l	m	n	o	
	5	p	q	r	s	t	u	v	w	x	y	z	{	}	~		
	6	'	a	b	c	d	e	f	g	h	i	j	k	l	m	n	o
	7	p	q	r	s	t	u	v	w	x	y	z	{	}	~		
	A		g	r	u
	B	-	7	4	0	0	0	0	0	0	0	0	0	0	0	0	0
	C	9	7	7	7	7	7	7	7	7	7	7	7	7	7	7	7
	D	3	4	4	4	4	4	4	4	4	4	4	4	4	4	4	4
1																	



11.1. MEMORY MAPPING

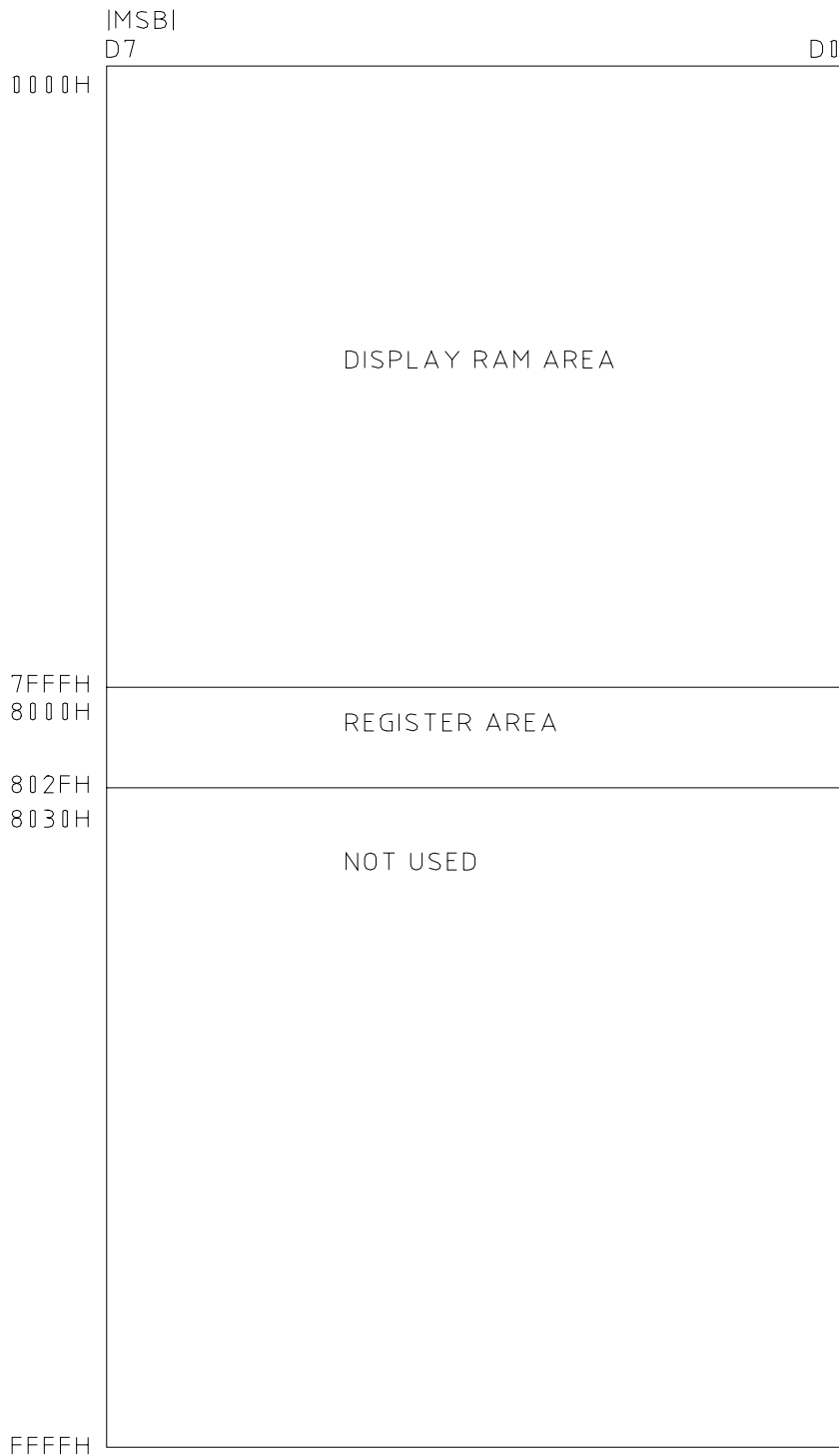



12. ELECTRO-OPTICAL CHARACTERISTICS

Item		Temp	Unit	Standard Value			Note
				Min	Typ	Max	
Operating Voltage	Vop	25°C	V		23		
Frame Frequency	f	25°C	Hz	64	75	100	(1)
Response Time	Ton	25°C	msec	-	200	250	(2)
	Toff	25°C		-	250	300	
Contrast Ratio($\theta=30^\circ$)	CR	25°C		2	4.5	-	
Viewing Angle(CR>2)	θ	25°C	Deg	20	30	-	

Contrast Ratio Definition

$$\text{Contrast Ratio} = \left\{ \frac{\text{Non-selected segment intensity}}{\text{Selected segment intensity}} \right\}^n$$

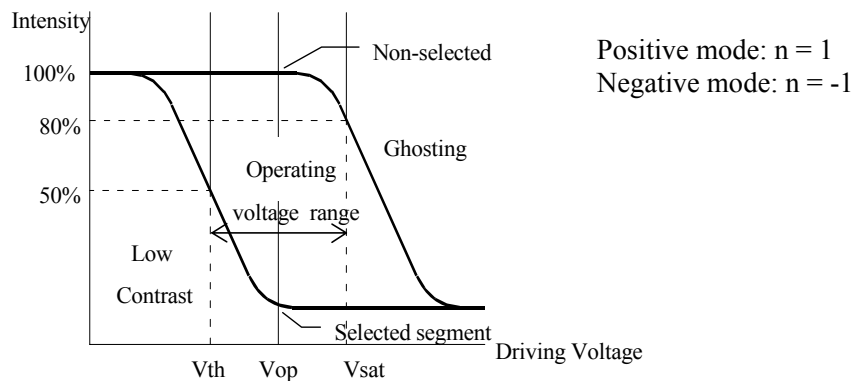

Viewing Angle Definition

θ : Angle between Viewer Direction and Normal.
($-90^\circ \leq \theta \leq 90^\circ$)

ϕ : Angle between Projection of Viewer Direction to X-Y plane and Y axis.
($0^\circ \leq \phi \leq 360^\circ$)

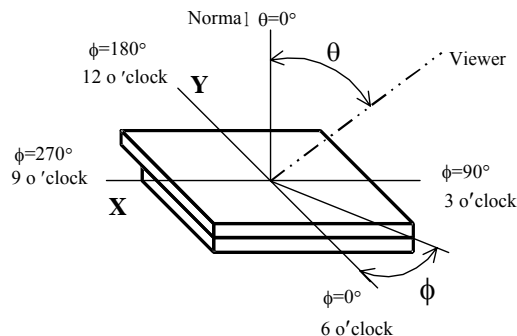

Measuring Condition

1. Driving Voltage: Same as Vop.
2. Driving Frequency: Same as Frame Frequency.



13. Quality Specifications

13.1 Inspection Condition

13.1.1 The inspection shall be performed by using 20W x 2 fluorescent lamps . Distance between LCD and fluorescent lamps should be 100 cm or more. Distance between LCD and inspector eyes should be 30 cm or more.

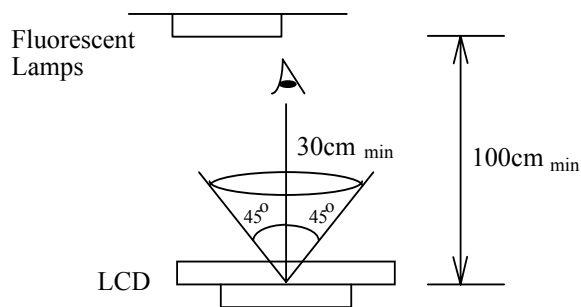

13.1.2 For transmissive displays a reflector (e.g. a white card) shall be placed behind the display.

13.1.3 Viewing direction for inspection is 45° from vertical against LCD.

13.2. Definition of Zone

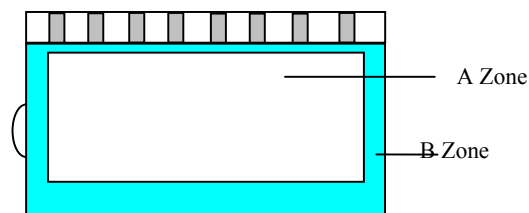

A Zone: Active display area (minimum viewing area).

B Zone: Non-active display area (outside viewing area).



13.3 Sampling Method: MIL-STD-105E.

13.4 Inspection level: Level II, Single Sampling.

Rank	Item		Criterion	AQL
Major	1. Display state	1. Segment short circuit.	1	0.4
		2. Open circuit (missing segment)		
		3. Contrast defect (dim, ghosting)		
		4. Segment defect (Pin hole, etc.)	6	
		5. Leakage	/	Ac:0 Re: 1
		6. No display, polarizers reverse applied		
	2. Dimension	1. Dimension out of specification (incl. PIN)	2	0.4
Minor	1. Non-display state	1. Spot, foreign material, line defect	3, 4, 5	1.0
		2. Rainbow, background color		
	2. Polarizer	1. Scratch	3, 4, 7	
		2. Bubble		
		3. Foreign material		
		4. Poor fixed position	8	
	3. Glass substrate	1. Chipped	9	
		2. Protruded, burred	10	
	4. PIN	1. Positioning	11	
		2. Epoxy coverage		
5. Silk screen	1. Positioning	12		
	2. Color			
	3. Semblance defect (Refer spot, line Standards)	3, 4		
Total				1.0

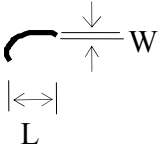
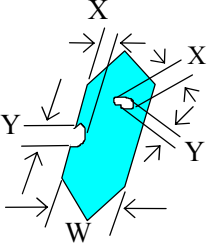

13.5 Inspection Items and Standards

No	Item	Criterion																				
1	Segment short, missing	Not exist																				
	Contrast defect	Refer to approved sample																				
2	Outside defect、 Positioning Color	Not exceed tolerance Refer to approved sample																				
3	Point defect, Black spot, dust (incl. Polarizer) $\phi = (X+Y)/2$	 <table border="1" data-bbox="917 730 1342 1021"> <thead> <tr> <th>Point Size</th> <th>Acceptable Qty.</th> </tr> </thead> <tbody> <tr> <td>$\phi \leq 0.10$</td> <td>2</td> </tr> <tr> <td>$0.10 < \phi \leq 0.20$</td> <td>1</td> </tr> <tr> <td>$0.20 < \phi \leq 0.25$</td> <td>0</td> </tr> <tr> <td>$0.25 < \phi \leq 0.30$</td> <td>0</td> </tr> <tr> <td>$\phi > 0.30$</td> <td>0</td> </tr> </tbody> </table> <p>Unit: mm</p>	Point Size	Acceptable Qty.	$\phi \leq 0.10$	2	$0.10 < \phi \leq 0.20$	1	$0.20 < \phi \leq 0.25$	0	$0.25 < \phi \leq 0.30$	0	$\phi > 0.30$	0								
Point Size	Acceptable Qty.																					
$\phi \leq 0.10$	2																					
$0.10 < \phi \leq 0.20$	1																					
$0.20 < \phi \leq 0.25$	0																					
$0.25 < \phi \leq 0.30$	0																					
$\phi > 0.30$	0																					
4	Line defect	 <table border="1" data-bbox="863 1149 1394 1413"> <thead> <tr> <th colspan="2">Line</th> <th>Acceptable Qty.</th> </tr> <tr> <th>L</th> <th>W</th> <th></th> </tr> </thead> <tbody> <tr> <td>---</td> <td>$0.015 \geq W$</td> <td>Disregard</td> </tr> <tr> <td>$3.0 \geq L$</td> <td>$0.03 \geq W$</td> <td rowspan="2">1</td> </tr> <tr> <td>$2.0 \geq L$</td> <td>$0.05 \geq W$</td> </tr> <tr> <td>$1.0 \geq L$</td> <td>$0.1 > W$</td> <td>0</td> </tr> <tr> <td>---</td> <td>$0.05 < W$</td> <td>Applied as point defect</td> </tr> </tbody> </table> <p>Unit: mm</p>	Line		Acceptable Qty.	L	W		---	$0.015 \geq W$	Disregard	$3.0 \geq L$	$0.03 \geq W$	1	$2.0 \geq L$	$0.05 \geq W$	$1.0 \geq L$	$0.1 > W$	0	---	$0.05 < W$	Applied as point defect
Line		Acceptable Qty.																				
L	W																					
---	$0.015 \geq W$	Disregard																				
$3.0 \geq L$	$0.03 \geq W$	1																				
$2.0 \geq L$	$0.05 \geq W$																					
$1.0 \geq L$	$0.1 > W$	0																				
---	$0.05 < W$	Applied as point defect																				
5	Rainbow	Not more than two color changes across the viewing area. Background color should refer to approved sample .																				
6	Segment pattern W = Segment width $\phi = (A+B)/2$	<p>1. Pin hole</p> <p>$\phi < 0.10\text{mm}$ is acceptable.</p>  <table border="1" data-bbox="940 1720 1386 1845"> <thead> <tr> <th>Width</th> <th>Acceptable of defect</th> </tr> </thead> <tbody> <tr> <td>$W < 0.4$</td> <td>$\phi \leq 1/2W$ and, $\phi \leq 0.2$</td> </tr> <tr> <td>$W \geq 0.4$</td> <td>$\phi \leq 1/3W$ and, $\phi \leq 0.25$</td> </tr> </tbody> </table> <p>Unit: mm</p>	Width	Acceptable of defect	$W < 0.4$	$\phi \leq 1/2W$ and, $\phi \leq 0.2$	$W \geq 0.4$	$\phi \leq 1/3W$ and, $\phi \leq 0.25$														
Width	Acceptable of defect																					
$W < 0.4$	$\phi \leq 1/2W$ and, $\phi \leq 0.2$																					
$W \geq 0.4$	$\phi \leq 1/3W$ and, $\phi \leq 0.25$																					

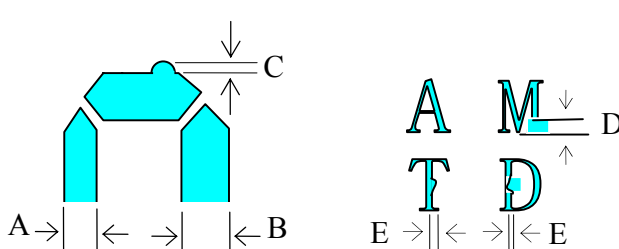
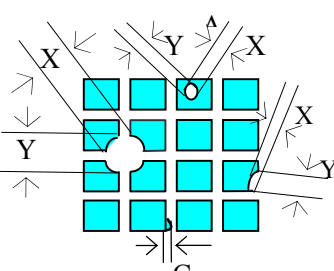

No	Item	Criterion												
		<p>2. Segment width acceptable.</p> $ A - B < 0.20 ; \quad D \leq 0.2$ $C \leq 0.1 \quad E \leq 0.15$  <p>3. Dot pattern</p>  <table border="1" data-bbox="1021 1097 1436 1254"> <thead> <tr> <th>Size</th> <th>Acceptable Qty.</th> </tr> </thead> <tbody> <tr> <td>$\phi < 0.1$</td> <td>Disregard</td> </tr> <tr> <td>$0.10 \leq \phi \leq 0.20$</td> <td>1</td> </tr> <tr> <td>$\phi > 0.20$</td> <td>0</td> </tr> </tbody> </table> <p>C: Shall not touch other dot(s). Unit: mm</p>	Size	Acceptable Qty.	$\phi < 0.1$	Disregard	$0.10 \leq \phi \leq 0.20$	1	$\phi > 0.20$	0				
Size	Acceptable Qty.													
$\phi < 0.1$	Disregard													
$0.10 \leq \phi \leq 0.20$	1													
$\phi > 0.20$	0													
7	Polarizer air bubble	<table border="1" data-bbox="766 1433 1260 1657"> <thead> <tr> <th>Size</th> <th>Acceptable Qty.</th> </tr> </thead> <tbody> <tr> <td>$\phi < 0.10$ or B Zone</td> <td>Disregard</td> </tr> <tr> <td>$0.10 < \phi \leq 0.20$</td> <td>2</td> </tr> <tr> <td>$0.20 < \phi \leq 0.50$</td> <td>1</td> </tr> <tr> <td>$0.50 < \phi$</td> <td>0</td> </tr> <tr> <td>Total</td> <td>2</td> </tr> </tbody> </table> <p>Unit: mm</p>	Size	Acceptable Qty.	$\phi < 0.10$ or B Zone	Disregard	$0.10 < \phi \leq 0.20$	2	$0.20 < \phi \leq 0.50$	1	$0.50 < \phi$	0	Total	2
Size	Acceptable Qty.													
$\phi < 0.10$ or B Zone	Disregard													
$0.10 < \phi \leq 0.20$	2													
$0.20 < \phi \leq 0.50$	1													
$0.50 < \phi$	0													
Total	2													
8	Polarizer mis-placement	Polarizer should neither extends to glass edge nor extends into seal.												

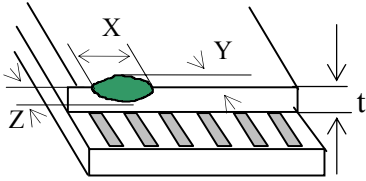
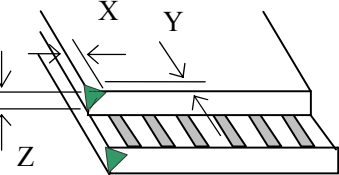
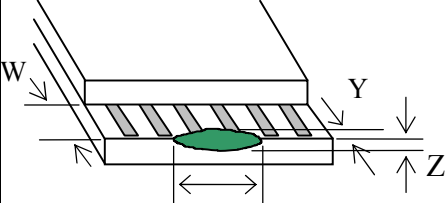
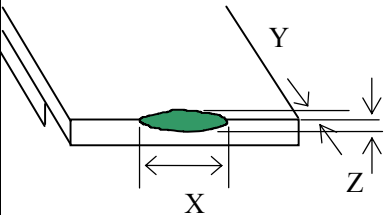

No	Item	Criterion																								
9	<p>Crack and chip</p> <p>Remark:</p> <p>X: Length direction</p> <p>Y: Short direction</p> <p>Z: Thickness direction</p> <p>t: Glass thickness</p> <p>a: LCD length</p> <p>W: Terminal Width</p> <p>F: seal width</p>	<p>1. General</p>  <table border="1" data-bbox="1027 573 1423 714"> <caption>Acceptable criterion</caption> <thead> <tr> <th>X</th> <th>Y</th> <th>Z</th> </tr> </thead> <tbody> <tr> <td>≤ 5mm</td> <td>shall not reach to 1F/3</td> <td>≤ t/2</td> </tr> </tbody> </table> <p>2. Corner</p>  <table border="1" data-bbox="1027 976 1423 1081"> <caption>Acceptable criterion</caption> <thead> <tr> <th>X</th> <th>Y</th> <th>Z</th> </tr> </thead> <tbody> <tr> <td>≤ 5mm</td> <td>shall not reach to F/3</td> <td>≤ t</td> </tr> </tbody> </table> <p>3. Crack on terminal</p>  <table border="1" data-bbox="1075 1429 1407 1503"> <caption>Acceptable criterion</caption> <thead> <tr> <th>X</th> <th>Y</th> <th>Z</th> </tr> </thead> <tbody> <tr> <td>≤ a/10</td> <td>≤ 0.4</td> <td>≤ t</td> </tr> </tbody> </table> <p>4. Other than terminal</p>  <table border="1" data-bbox="1027 1809 1423 1915"> <caption>Acceptable criterion</caption> <thead> <tr> <th>X</th> <th>Y</th> <th>Z</th> </tr> </thead> <tbody> <tr> <td>≤ a/10</td> <td>shall not reach to F/3</td> <td>≤ t/3</td> </tr> </tbody> </table>	X	Y	Z	≤ 5mm	shall not reach to 1F/3	≤ t/2	X	Y	Z	≤ 5mm	shall not reach to F/3	≤ t	X	Y	Z	≤ a/10	≤ 0.4	≤ t	X	Y	Z	≤ a/10	shall not reach to F/3	≤ t/3
X	Y	Z																								
≤ 5mm	shall not reach to 1F/3	≤ t/2																								
X	Y	Z																								
≤ 5mm	shall not reach to F/3	≤ t																								
X	Y	Z																								
≤ a/10	≤ 0.4	≤ t																								
X	Y	Z																								
≤ a/10	shall not reach to F/3	≤ t/3																								

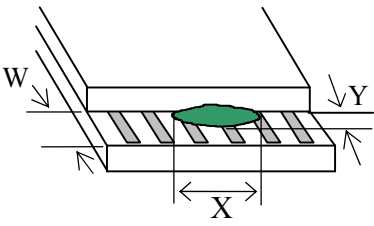
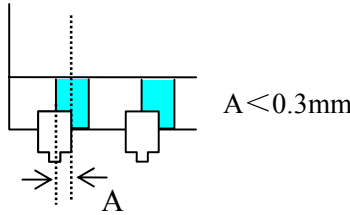
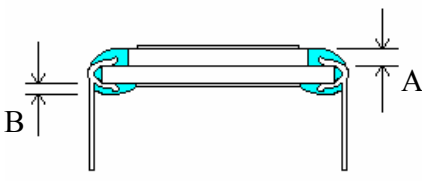

No	Item	Criterion
10	Protruded W: Terminal Width	 <p>Acceptable criteria: $Y \leq 1/5W$</p>
11	Pin	<p>1. Positioning</p>  <p>$A < 0.3\text{mm}$</p> <p>2 Epoxy coverage</p>  <p>A、 B Epoxy Maximum height shall extend above front rear polarizer surface</p> <p>3. No stain, rust nor discoloration of the insulating portion shall be allowed.</p>
12	Total no. of acceptable defect	<p>A. Zone</p> <p>Maximum 4 non-conformities per one unit. Defect distance: each point to be separated over 5mm</p> <p>B. Zone</p> <p>It is acceptable when it is no trouble for quality and assembly in customer's end product.</p>



13.6 Reliability Standards

- 1 Under normal operating and storage conditions a lifetime of 50,000 hours is expected.
- 2 Reliability test condition:

Item	Condition	Time(hrs)	Assessment
High temp. storage	+70°C	240	No abnormalities in functions and appearance
Low temp. storage	-20°C	240	
Humidity	40°C / 90%RH	240	
Change of temperature	- 20°C ← 25°C → 70°C (60 min ← 5 min → 60min)	5 cycles	

3. In case of mass production, every order shall draw 10pcs. of samples to conduct a reliability test in according to the following condition:

Item	Condition	Time (hrs)
High temp. storage	+70°C	48
Low temp. storage	-20°C	48
Humidity	40°C / 90%RH	48

4. Recovery time should be 24 hours minimum.

13.7. Cautions for use

Pay attention to following points of handling the TAB LCD module:

1. Take utmost care when handling as these products are made of glass. Any strong mechanical impact due to falling, etc. may cause damage(breakage or cracking).
2. Polarizer is made of soft material and is easily damaged, take utmost care when handling . The protective film attached is to prevent scratch and protect against dirt, it is recommended that this film should be kept sealing before use.



3. Clean polarize with a soft cloth.
4. Do not touch the connection terminals of the display with bare hand, it will cause disconnection or defective insulation of terminals
5. Avoid use or extended storage at high temperature and high humidity. For extended storage, select a storage area where the temperature is $20\pm 8^{\circ}\text{C}$ and the relative humidity is less than 65%
6. Do not expose the display to the direct sunlight or UV light.
7. Be careful not to touch or swallow liquid crystal that might leak from a damaged cell. Any liquid crystal adheres to skin or clothes, wash it off immediately with soap and water.

Limited Warranty

TRI-T modules are not consumer products, but may be incorporated by TRI-T's customers into consumer products or components thereof, TRI-T does not warrant that its modules and components are fit for any such particular purpose.

1. The liability of TRI-T is limited to repair or replacement on the terms set forth below. TRI-T will not be responsible for any subsequent or consequential events or injury or damage to any personnel or user including third party personnel and/or user. Unless otherwise agreed in writing between TRI-T and the customer, TRI-T will only replace or repair any of its LCD which is found defective electrically or visually when inspected in accordance with TRI-T QUALITY INSPECTION STANDARD.
2. No warranty can be granted if any of the precautions state in handling liquid crystal display above has been disregarded. Broken glass, scratches on polarizer mechanical damages as well as defects that are caused accelerated environment tests are excluded from warranty.
3. In returning the module, they must be properly packaged; there should be detailed description of the failures or defect.