

PKF series General information

- SMD and through hole versions with ultra-low component height 8.0 mm (0.315 in.)
- Up to 87% efficiency at full load
- Safety requirements in accordance with EN60950
- MTTF >10 million hours at +50°C case temperature (+40°C ambient)
- Low EMI

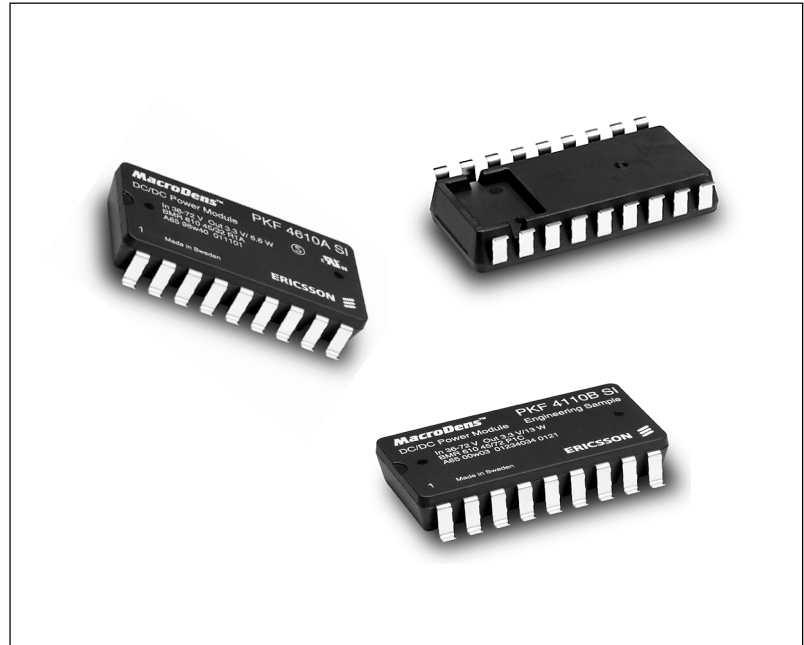

Patents

US: D357901 DE: M94022763

The MacroDens™ PKF family of true component level on-board DC/DC power modules are intended as distributed power sources in decentralized power systems. Utilization of thick film technology and a high degree of silicon integration has made it possible to achieve a MTTF of more than 10 million hours. The high reliability and the very low heights of these DC/DC power modules makes them particularly suited for Information Technology and Telecom (IT&T) applications, with board spacing down to 15 mm or 0.6 in. They are optimized for an operational ambient temperature range in compliance

with present and future application needs, including non temperature controlled environments. The mechanical design offers surface mount and through-hole versions, delivered in ready-to-use tubes, trays or tape & reel packages, and compatibility with semi and fully aqueous cleaning processes. The PKF series is manufactured in highly automated production lines using SMT, laser trimming, 100% burn-in and ATE final inspection.

Ericsson Microelectronics AB has been an ISO 9001 certified supplier since 1991. For a complete product program please reference the back cover.

Environmental Characteristics

Characteristics	Test procedure & conditions		
Vibration (Sinusoidal)	JESD 22-B103 (IEC 68-2-6 F _c)	Frequency Amplitude Acceleration Number of cycles	10...500 Hz 0.75 mm 10 g 10 in each axis
Random vibration	MIL-STD-883 Method 2026 (IEC 68-2-34 E _d)	Frequency Acceleration density spectrum Duration Reproducibility	10...500 Hz 0.5 g ² /Hz 10 min in 3 directions medium (IEC 62-36)
Shock (Half sinus)	JESD 22-A104 (IEC 68-2-14 N _a)	Peak acceleration Shock duration	200 g 3 ms
Temperature change	JESD 22-A101 (IEC 68-2-3 C _a with bias)	Temperature Humidity Duration	85°C 85% RH 1000 hours
Accelerated damp heat	JESD 22-B104 (IEC 68-2-27 E _a)	Temperature Number of cycles	-40°C...+125°C 500
Aggressive environment	JESD 22-A-A107 (IEC 68-2-11 K _a)	Duration Temperature	96 h 35°C
Resistance to soldering temp ^{1) 2)}	JESD 22-B106 (IEC 68-2-20 T _b 1A)	Temperature, solder Duration	260°C 10...13 s
High temp Storage life	JESD22-A10	Temperature Duration	125°C 1000hrs
Lead Integrity	JESD22-B105	Number of cycles	2
Solderability	JESD22-B102		
Operational life test		Temperature Maximum load Input voltage on Input voltage off Duration	85°C 9min 3min 1000hrs
Moisture reflow Sensitive classification	J-STD-020	Level 1	

1) Applies to through-hole versions

2) For surfacemount versions please see soldering profile page 4.

Mechanical Data

Through-hole version

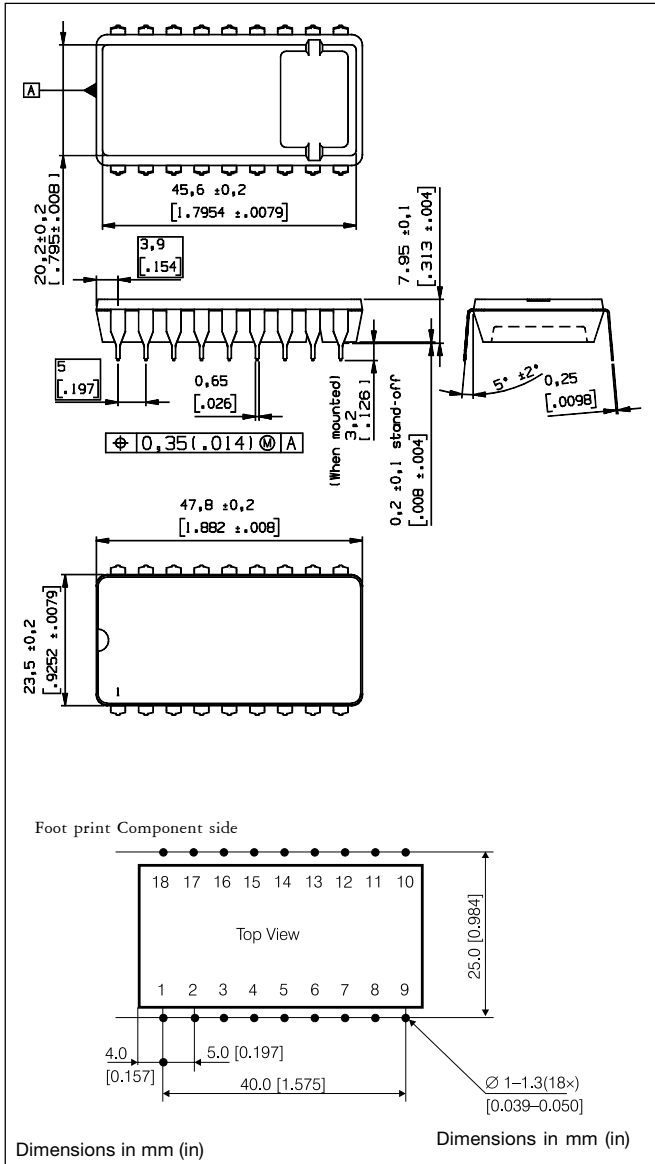

Surface-mount version

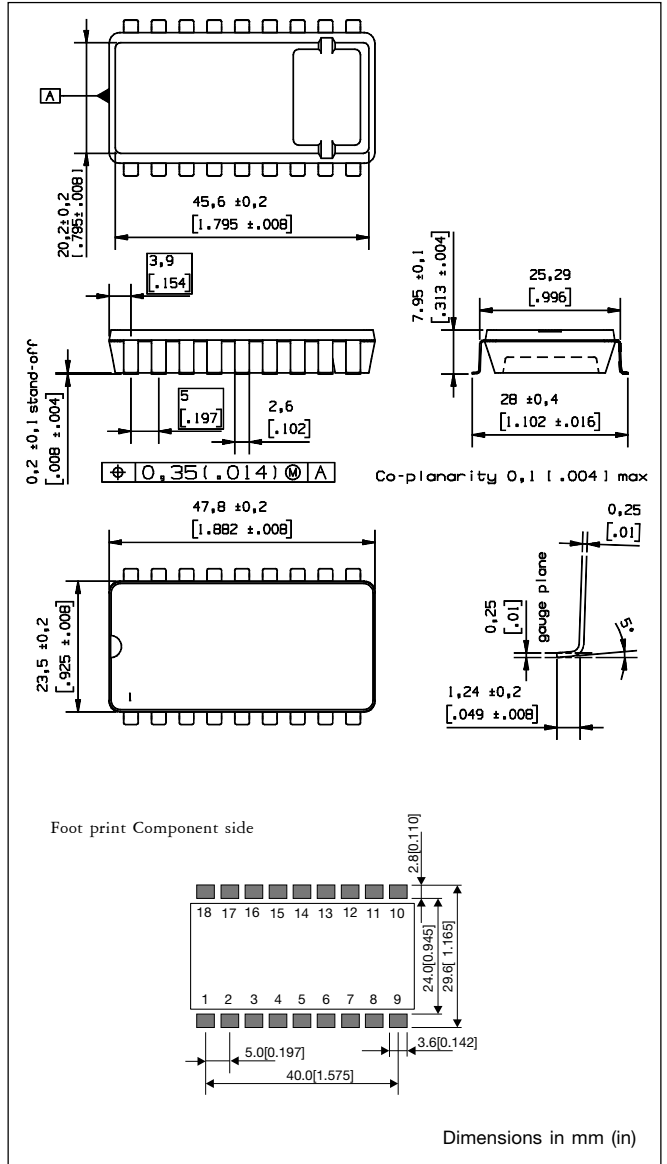

Weight

Maximum 20 g (0.71 oz).

Case

The case consists of semiconductor grade epoxy with embedded pins.
 Coefficient of thermal expansion (CTE) is typ.
 15 ppm/°C.

Connection Pins

Base material is copper (Cu), first plating is nickel (Ni) and second (outer) plating is palladium (Pd).

Thermal Data

Two-parameter model

This model provides a more precise description of the thermal characteristics to be used for thermal calculations. Thermally the power module can be considered as a component and the case temperature can be used to characterize the properties. The thermal data for a power module with the substrate in contact with the case can be described with two thermal resistances. One from case to ambient air and one from case to PB (Printed circuit Board). The thermal characteristics temperature can be calculated from the following formula:

$$T_{PB} = (T_C - T_A) \times (R_{th\ C-PB} + R_{th\ C-A}) / R_{th\ C-A} - P_{diss} \times R_{th\ C-PB} + T_A$$

Where:

- P_{diss} : dissipated power, calculated as $P_O \times (I/h-1)$
- T_C : max average case temperature
- T_A : ambient air temperature at the lower side of the power module
- T_{PB} : temperature in the PB between the PKF connection pins
- $R_{th\ C-PB}$: thermal resistance from case to PB under the power module
- $R_{th\ C-A}$: thermal resistance from case to ambient air
- v : velocity of ambient air

$R_{th\ C-PB}$ is constant and $R_{th\ C-A}$ is dependent on the air velocity. Free convection is equal to an air velocity of approx. 0.2 – 0.3 m/s. See figure below.

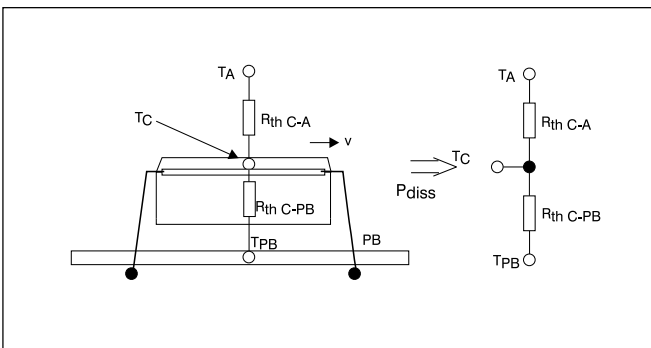
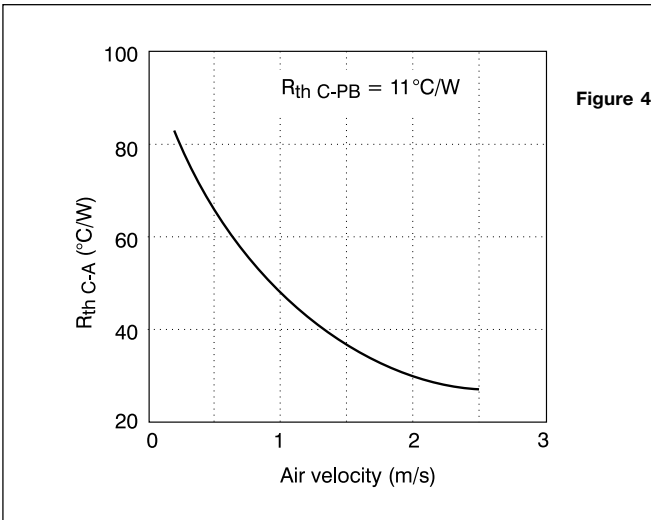

Reflow Soldering Information

The PKF series of DC/DC power modules are manufactured in surface mount technology. Extra precautions must therefore be taken when reflow soldering the surface mount version. Neglecting the soldering information given below may result in permanent damage or significant degradation of power module performance. The PKF series can be reflow soldered using IR, Natural Convection, Forced Convection or Combined IR/Convection Technologies. The high thermal mass of the component and its effect on ΔT (°C) requires that particular attention be paid to other temperature sensitive components.

IR Reflow technology may require the overall profile time to be extended to approximately 8–10 minutes to ensure an acceptable ΔT . Higher activity flux may be more suitable to overcome the increase in oxidation and to avoid flux burn-up. The general profile parameters detailed in the diagram, with this extended time to reach peak temperatures, would then be suitable. **Note!** These are maximum parameters. Depending on process variations, an appropriate margin must be added.

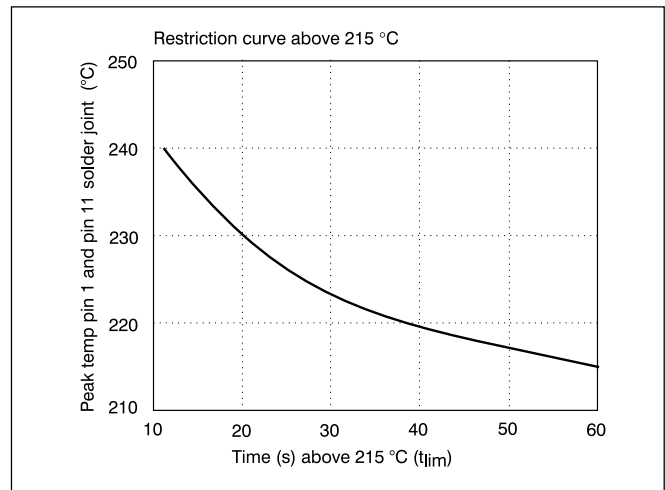
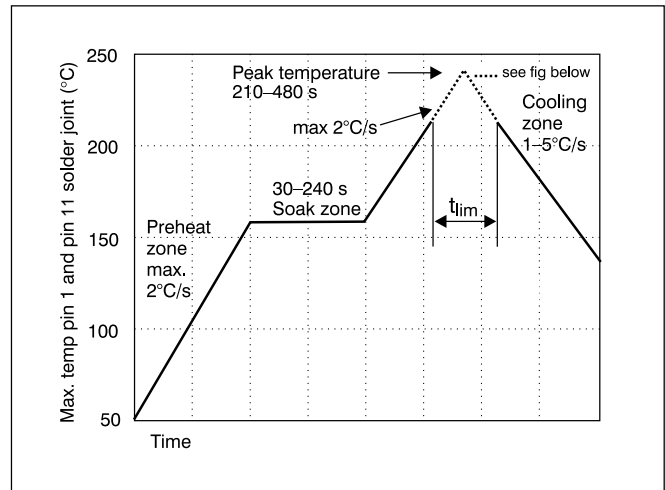

Palladium plating is used on the terminal pins. A pin temperature (T_p) in excess of the solder fusing temperature (+183°C for Sn/Pb 63/37) for more than 25 seconds and a peak temperature above 195°C, is required to guarantee a reliable solder joint. Both pin 1 and pin 11 must be monitored. **No responsibility is assumed if these recommendations are not strictly followed.**

Delivery Package Information

Tubes

The PKF-series is delivered in tubes (designated by /A) with a length of 500 mm (19.69 in), see fig. 2.

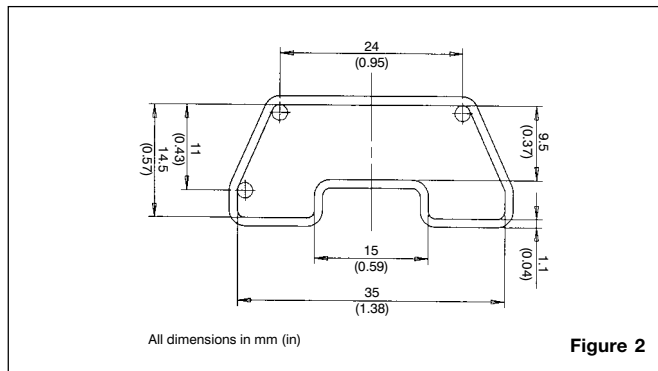

Figure 2

Specification

Material: Antistatic coated PVC
 Max surface resistance: $10^{11}\Omega/\square$
 Color: Transparent
 Capacity: 10 power modules/tube
 Weight: Typ. 60 g
 End stops: Pins

Trays

SMD versions, SI, can be delivered in standard JEDEC trays (designated by /B) on request, see fig. 3. For more information, please contact your local Ericsson sales office.

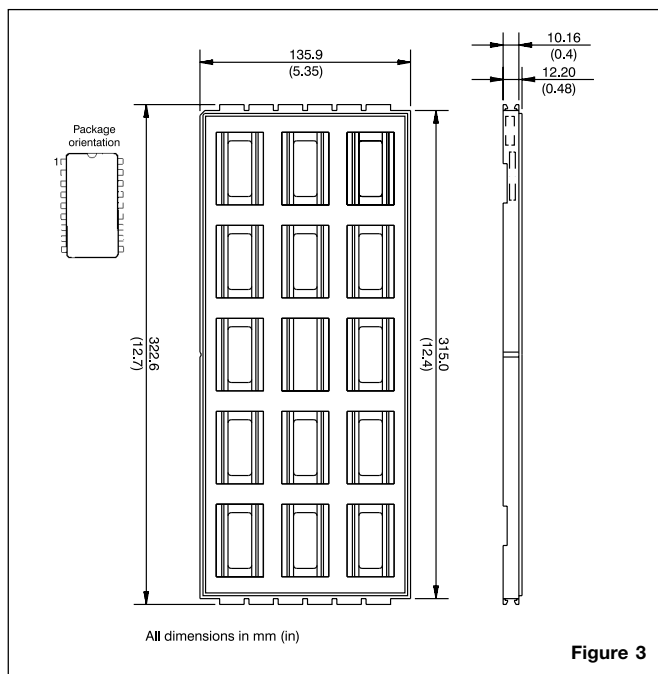

Figure 3

Specification

Material: Polypropylene (PP)
 Max temperature: 125°C
 Max surface resistance: $10^5\Omega/\square$
 Color: Black

Capacity: 15 power modules/tray
 Stacking pitch: 10.16 mm
 Weight: Typ. 130 g
 Min. order quantity: 150 pcs (one box contains 10 full trays)

Tape & Reel

SMD versions, SI, can be delivered in standard tape & reel package (designated by /C) on request, see fig. 4. For more information, please contact your local Ericsson sales office.

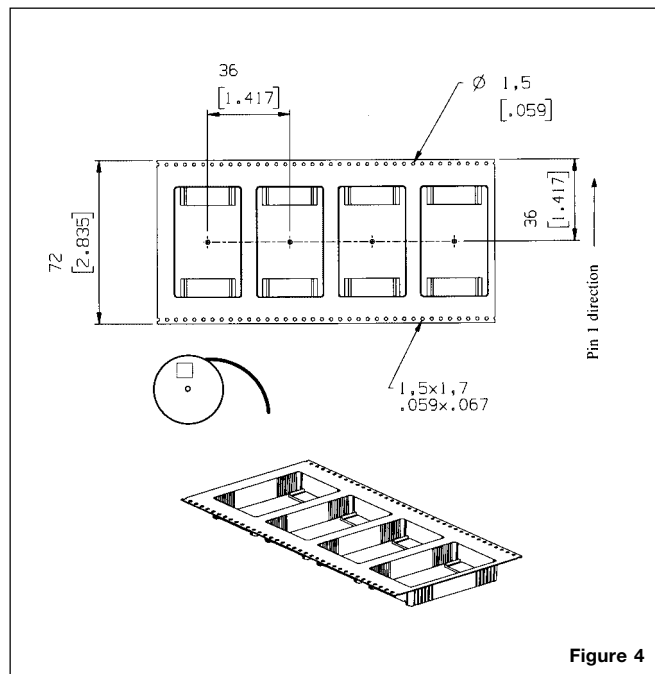

Figure 4

Specification

Tape material: Conductive polystyrene (PS)
 Tape width: 72 mm
 Tape pitch: 36 mm
 Max surface resistance: $10^5\Omega/\square$
 Tape color: Black
 Cover tape color: Transparent
 Reel diameter: 13"
 Reel hub diameter: 4"
 Reel capacity: 150 power modules/reel
 Full reel weight: Typ. 3.7 kg
 Min. order quantity: 300 pcs (one box contains two reels)

Quality

Reliability

Meantime to fail (MTTF) is calculated to >10 million hours at full output power and a case temperature of +50°C ($T_A = +40^\circ\text{C}$), using the Ericsson failure rate data system. The Ericsson failure rate data system is based on field failure rates and is continuously updated. The data corresponds to actual failure rates of components used in Information Technology and Telecom equipment in temperature controlled environments ($T_A = -5 \dots +65^\circ\text{C}$). The data is considered to have a confidence level of 90%. For more information see Design Note 002.

Quality Statement

The products are designed and manufactured in an industrial environment where quality systems and methods like ISO 9000, 6 σ and SPC, are intensively in use to boost the continuous improvements strategy. Infant mortality or early failures in the products are screened out by a burn-in procedure and an ATE-based final test. Conservative design rules, design reviews and product qualifications, plus the high competence of an engaged work force, contribute to the high quality of our products.

Warranty

Ericsson Microelectronics warrants to the original purchaser or end user that the products conform to this Data Sheet and are free from material and workmanship defects for a period of five (5) years from the date of manufacture, if the product is used within specified conditions and not opened. In case the product is discontinued, claims will be accepted up to three (3) years from the date of the discontinuation. For additional details on this limited warranty please refer to Ericsson Microelectronics AB's "General Terms and Conditions of Sales", or individual contract documents.

Limitation of liability

Ericsson Microelectronics does not make any other warranties, expressed or implied including any warranty of merchantability or fitness for a particular purpose (including, but not limited to, use in life support applications, where malfunctions of product can cause injury to a person's health or life).

Information given in this data sheet is believed to be accurate and reliable. No responsibility is assumed for the consequences of its use nor for any infringement of patents or other rights of third parties which may result from its use. No license is granted by implication or otherwise under any patent or patent rights of Ericsson Microelectronics. These products are sold only according to Ericsson Microelectronics' general conditions of sale, unless otherwise confirmed in writing. Specifications subject to change without notice.

Product Program

V _i	V _o /I _o max		Part No.		
	O/P 1	O/P 2	P _o max	Through Hole	SMD
18-36 Vdc	3.3V/2.0A 5V/1.2A 5V/2.0A 12V/1.0A		6.6W 6W 10W 12W	PKF 2610A PI PKF 2611 PI PKF 2111A PI PKF 2113A PI	PKF 2610A SI PKF 2611 SI PKF 2111A SI PKF 2113A SI
36-75 Vdc	1.8V/5A 2.1V/1.5A 2.5V/4.4A 3.3V/1.5A 3.3V/2.0A 3.3V/3.0A 3.3V/4.0A 5V/1.2A 5V/2.0A 5V/3.0A 12V/0.6A 3.3V/2.1A +5V/1.0A +5V/1.0A +12V/0.5A +12V/0.84A	+5V/0.5A -5V/1.0A +3.3V/1.0A -12V/0.5A -12V/0.84A	9W 3W 11W 5W 6.6W 9.9W 13.2W 6W 10W 15W 7W 9.4W 6W 6W 6W 10W	PKF 4310 PI PKF 4510 PI PKF 4610A PI PKF 4910A PI *) PKF 4611 PI PKF 4111A PI **) PKF 4211A PI PKF 4713 PI PKF 4622 PI PKF 4628 PI PKF 4621 PI	PKF 4918B SI PKF 4310 SI PKF 4919B SI PKF 4510 SI PKF 4610A SI PKF 4910A SI PKF 4110B SI PKF 4611 SI PKF 4111A SI PKF 4211A SI PKF 4713 SI PKF 4928A SI PKF 4622 SI PKF 4628 SI PKF 4621 SI PKF 4121A SI
18-75 Vdc	3.3V/1.5A 5V/1.2A 7V/0.86A 12V/0.67A		5W 6W 6W 8W	PKF 5510 PI PKF 5611 PI PKF 5617 PI PKF 5713 PI	PKF 5510 SI PKF 5611 SI PKF 5617 SI PKF 5713 SI

*) PKF 4910A PI NS

**) PKF 4111A PI NS

NS = versions without synchronization function

Ericsson Microelectronics

SE-164 81 KISTA, Sweden

Phone: +46 8 757 5000

www.ericsson.com/microelectronics

For local sales contacts, please refer to our website

or call: Int. +46 8 757 4700, Fax: +46 8 757 4776

The latest and most complete information can be found on our website!

Data Sheet

EN/LZT 146 57 R1A

© Ericsson Microelectronics AB, March 2001